

Safety foot switches

TFH 232-...üdr

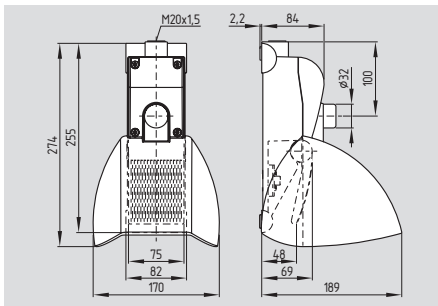

- 2 contacts
- Metal enclosure
- Protective shield with wide opening
- Low pedal height
- High level of stability
- Cable entry M20 x 1.5

Technical data

Standards:	IEC/EN 60947-5-1 DIN VDE 0660-200 BG-GS-ET-15
Enclosure, Cover, Protective shield:	aluminium die-cast, powder-coated, RAL 9006
Pedal:	glass-fibre reinforced thermoplastic
Connection:	screw terminals
Cable section:	max. 2.5 mm ² (incl. conductor ferrules)
Cable entry:	1 x M20 x 1.5
Protection class:	IP 65 to IEC/EN 60529
Switching system:	⊖ IEC 60947-5-1 slow action, NC contact with positive break
Contacts:	1 NO / 1 NC
U _{imp} :	6 kV
U _i :	500 V
I _{the} :	10 A
Utilisation category:	AC-15, DC-13
I _e /U _e :	4 A / 230 VAC 1 A / 24 VDC
Max. fuse rating:	6 A gG D-fuse to DIN EN 60269-1
Ambient temperature:	- 25 °C ... + 70 °C
Mechanical life:	> 1 million operations

Contact variants

1 NO/1 NC

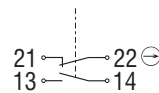

Approvals



Ordering details

TFH 232-11-üdr

Mode of operation

