

Safety Sensor CSS 180
Product Information



CSS 180

CSS 180

- PDF-M / EN 60947-5-3
- EN 954- 1 Control Category 4
- IEC 61508, suitable for use in SIL 3 applications
- BG Type-Certification in preparation



The Safety Sensor CSS 180 and corresponding Actuator CST 180

Application

The CSS 180 non-contact, electronic safety sensor is designed for application in safety circuits and is used for monitoring the position of movable safety guards. In this application the safety sensor monitors the closed position of hinged, sliding or removable guards with the aid of a coded actuator.

The CSS 180 Safety Sensor fulfils the requirements for proximity devices with defined behaviour under fault conditions according to EN 60947-5-3 with the classification PDF-M (self-monitoring). Furthermore, the requirements of Control Category 4 to EN 954-1 are also satisfied.

The standard IEC EN 61508, the latest specification for ensuring universal compliance to international safety standards, was used as a guideline for the development of the safety sensor. Consequently, the CSS 180 safety sensor can be used in SIL 3 applications to IEC 61508.

Function, principle of operation

The CSS 180 Safety Sensor and CST 180 actuator are a matched pair. As the actuator approaches the sensor, the sensor excites the actuator at a predetermined resonant frequency and then reads back the actuator oscillation. The sensor evaluates the actuator frequency and its distance to the actuator.

Identification of the actuator is interpreted as a closed guard by the safety sensor, and the safety outputs are enabled.

The safety sensor is a dual channel design with two short-circuit proof, safe PNP outputs, each of which can switch up to 500 mA. Due to continuous internal function tests and the monitoring of the safety outputs, a number of CSS 180 Safety Sensors can be wired in series without detriment to the control category. Series wired safety sensors continue to fulfill the requirements of Control Category 4 according to EN 954-1.

Properties, mounting and use

Key features of the Safety Sensor CSS 180:

- Non-contact, no wear
- Can be flush-mounted
- Assured operating distance S_{ao} 7 mm, assured release distance S_{ar} 9.5 mm
- Accurate, repeatable switching points, hysteresis 0.5 mm, repeatability 0.2 mm, can be actuated offset
- Monitored series wiring of the sensors in Control Category 4 to EN 954-1.
- Max. length of the sensor chain 200 m (depending on output load and cable cross-section).
- 2 PNP safety outputs, 24 VDC, 500 mA rating per output, short-circuit proof
- Visual diagnostics via LED.
- Electronic diagnostic output 24 VDC, 50 mA.
- Advance warning on approaching hysteresis area.
- Advance fault warning, enabling controlled machine shut-down.
- Control Category 4 to EN 954-1.
- Self-monitoring, PDF-M classification to EN 60947-5-3.
- Suitable for use in applications up to SIL 3 to IEC 61508, PFH value $< 5,5 \times 10^{-9}$



Misalignment in the safety guard can be easily compensated

The application, mounting and usage

Both the sensor and actuator are small and compact. They can be fitted easily in any position on a machine guard or other object to be monitored. The actuator has two sets of fixing holes for attachment parallel or square to the mounting surface. The sensor can be attached using a mounting clamp (accessory) or with the two M18 nuts (supplied).

If required, both the actuator and the sensor can be flush mounted using the M18 x 1 mm standard housing threads.

The sensor and actuator are encapsulated, vibration-proof and suitable for application in harsh, dusty or dirty environments. They comply to the requirements for the degree of protection IP 67.

Adjustment is simple. A large switching distance and the possibility of also being able to operate the sensor and actuator with an offset enables large tolerances to be accommodated on the safety guard.

The small hysteresis of 0.5 mm and a repeatability of 0.2 mm result in precise, repeatable switching points throughout its operational lifetime.

The correct functioning of the sensor, a fault in the sensor output, a crosswire short and finally actuation of the sensor itself by the actuator are signalled by the visual diagnostic 3 colour LED. The LED can also be used as an adjustment aid during fitting.

The electronic diagnostic output indicates an actuated sensor. If a sensor is operated near the limit of its switching distance, for example due to the sagging of a guard door, it is detected even before the safety outputs are disabled, and results in an intermittent pulse on the electronic diagnostic output and visual diagnostic LED.

In a similar way, faults which do not immediately compromise the safe operation of the sensor, for example a crosswire short, are signalled as an advance warning. The machine can in this case be run down in a controlled manner.

Wiring in Series

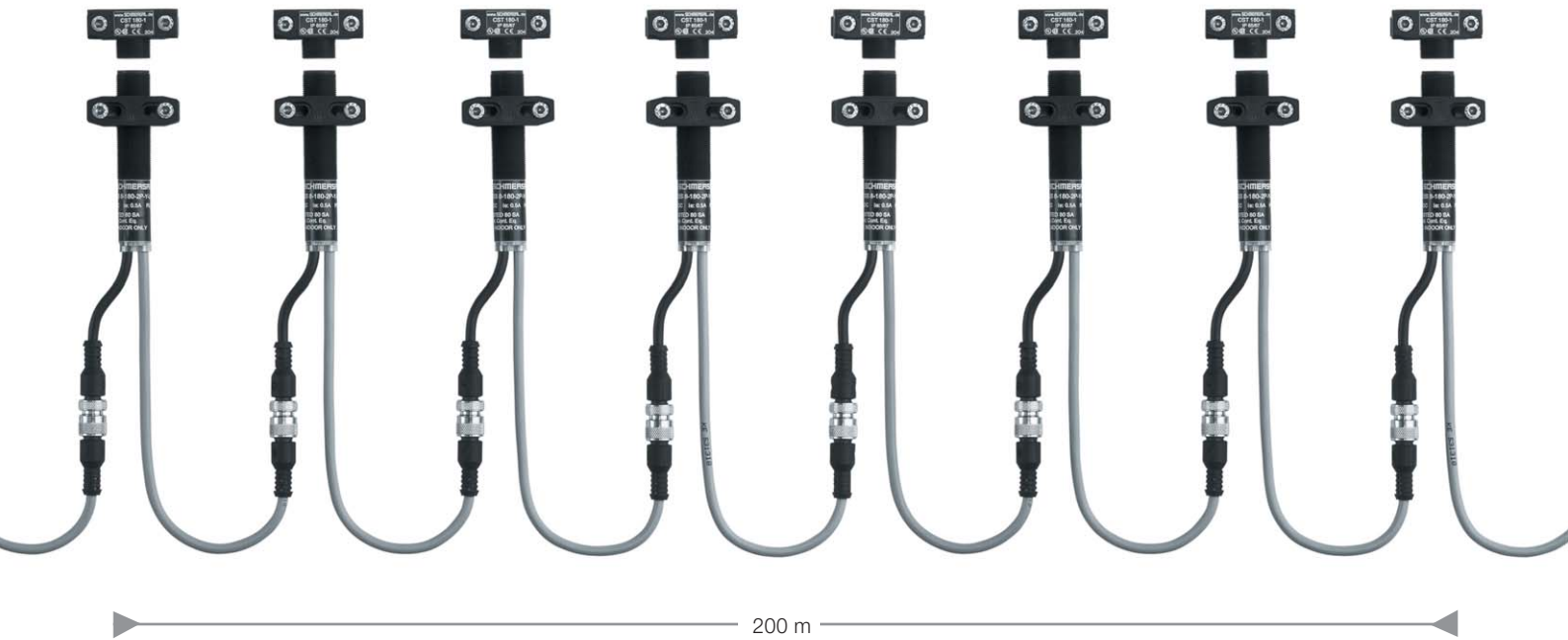

Series wiring of the Safety Sensor CSS 180:

A number of CSS 180 safety sensors can be wired together in series to form a chain. The redundant outputs of the first sensor are in this case wired to the inputs of the second sensor, and so on. The safety sensors in the chain are self-monitoring. The last sensor in the chain provides the two short-circuit proof, PNP outputs each rated at 500 mA for further connection to the safety control circuit. The safety requirements according to EN 954-1, Control Category 4 remain fulfilled for the complete chain. Faults within the chain, e.g. a cross-wire short, are detected. This includes faults in the wiring to the safety control monitor, which are also automatically detected.

To make cable routing and interconnection of the safety sensors as simple as possible, a wide range of pre-wired options are available:

For large, extensive guard systems, the Safety Sensor is available with separate input and output cables. The series wired safety sensors can then be built up to a length of over two hundred metres by "daisy chaining" the devices. When the cables are routed in control cable channels, the cables do not need to be shielded. The Y in the part number of the Safety Sensor CSS 180 identifies this version.

For compact systems, or where the control cables are parallel routed to a centralised control cabinet, the input and output leads of the safety sensor are combined in one cable. The series wiring of a number of sensors in this case can be realised in the control cabinet or junction box. This version is identified by an M in the part number of the Safety Sensor CSS 180.

A single cable version is available for individual sensor monitoring and is also suitable for the first sensors in a series. The E in the part number of the Safety Sensor CSS 180 identifies this version.

Note on the total length of a safety sensor chain

The voltage drop over a long sensor chain should be taken into account when planning cable routing.

The exact value of the operating voltage, wire cross-section and cable length, its temperature, the number of sensors connected and the input load of the safety control monitor are all factors that must be considered.

An approximately 200 m long sensor chain consisting of six sensors has at 20°C, 100 mA input current into the safety control monitor and 0.5 mm² cable cross-section, a voltage drop of approximately 1.5 V. If junction boxes are installed, a cable with 1.5 mm² cross-section should be laid between the junction boxes. When the cables are routed in control cable channels, shielding is not necessary. The cables must however be routed separately from supply and power cables. Local sources of external interference must be properly suppressed.

The power supply for the CSS 180 safety sensors must provide protection against permanent overvoltage. Therefore, SELF or PELF mains supply units are recommended. The maximum permissible fuse protection for the sensor chain is 1.6 A gL/gG.



Diagnostics

Visual diagnostics is achieved using an LED in the end cap of the safety sensor. The operating state is indicated using three different colours. Supply voltage, sensor actuation, operation near critical limits (sensor operation near max. switching distance, too high an ambient temperature) and faults in external wiring are indicated. In this way maintenance is simplified. Misalignment, for example due to the sagging of a safety guard, is indicated before the safe enabling outputs switch off.

Diagnostics



The diagnostic function of the Safety Sensor CSS 180

The safety sensor indicates the operating state and faults in three colours in the transparent end cap. The electronic diagnostic output signals faults before the safety outputs switch off and enables a controlled shut-down in emergency.

Function table of visual diagnostic LED, electronic diagnostic output and safety outputs

Sensor condition	Diagnostic LED colour in the sensor end cap	Electronic diagnostic output 24 VDC, 50 mA	Safety outputs
No target/ Power on	Green	0 V	0 V
Actuated	Yellow	24 V	24 V
Actuated in the limit area	Flashes yellow	2 Hz cycle	24 V
Fault	Flashes red	3 s delay 24 V -> 0 V	1 min delay 24 V -> 0 V

Visual diagnostic (red)	Cause of fault
1 pulse	Fault on Output Y1
2 pulses	Fault on Output Y2
3 pulses	Cross-wire short Y1/Y2
4 pulses	Ambient temperature too high
5 pulses	Incorrect or defective actuator
Continuous	Internal fault

Six different fault conditions are signalled by the diagnostic LED flashing with predefined pulse sequences or with continuous red light.

Mode of operation: Diagnostic LED

The green LED signals that the sensor is ready for operation. The supply voltage is present and there are no faults. The sensor is not actuated.

When the CSS 180 sensor is actuated by the CST 180 target, the LED changes from green to yellow. The safety outputs switch to enable.

If the actuator is near the limit of the sensor switching distance, the yellow LED flashes. The safe outputs remain enabled and the sensor can be readjusted before the safety outputs stop the machine. Errors in the actuator coding or the sensor outputs are signalled by a red flashing LED. The safe outputs then switch off after a delay of one minute. An internal fault is indicated by a continuous red LED and, if safe operation is not ensured, results in an immediate disabling of the safety outputs.

Mode of operation: Electronic diagnostic output

The short-circuit proof electronic diagnostic output can be used for central monitoring or control operations, for example in a PLC. In normal operation, the diagnostic output is high (+ 24 VDC) when the door is closed, i.e. the sensor is actuated by the target.

If a sensor is operating near the limit of the sensor switching distance, for example due to a misaligned guard, the diagnostic output sends a 2 Hz pulse sequence. The fault can then be rectified before the target becomes completely misaligned, i.e. outside the maximum switching range, and disables the outputs.

A fault is not only indicated by the red LED, but also by the electronic diagnostic output, which switches to low after a 3 second delay. In combination with the safety outputs (which, unless safe operation is not ensured, disable after a delay of 1 minute) it is therefore possible to bring the production process to a stop in a controlled manner.

Mode of operation: Safety outputs

The opening of a guard door disables the safe outputs of the CSS 180 sensor immediately.

Faults, where the safe functioning of a safety sensor can no longer be assured, also lead to the immediate disabling of the safe outputs. A fault that does not immediately effect the function of a safety sensor, for example due to a cross-wire short, does not result in an immediate disabling of the safe outputs. The diagnostic output switches to low and the safe outputs remain enabled.

The production process is not stopped abruptly and the machine can be set to a hold position. If the fault is still present after one minute, the safe outputs disable. After fault rectification, the sensor can be reset by opening and closing the relevant guard door. The safe outputs enable and allow a restart. This prevents unexpected (automatic) start up.

Switching distances, flush mounting, dimensions

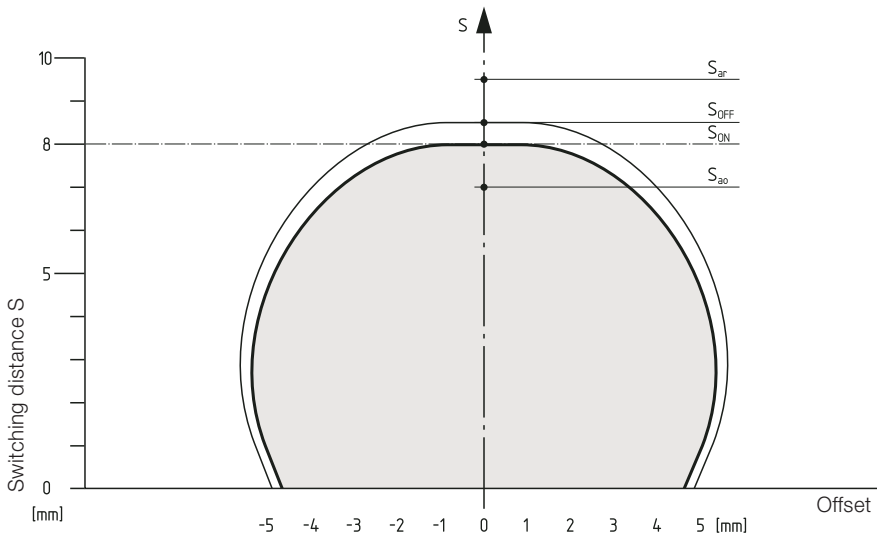

Typical response range of the sensor CSS 180

S_{ON} Switch-on point $S_{ON} < S_H < S_{OFF}$
 S_{OFF} Switch-off point $S_H = \text{Hysteresis area}$

S_{ao} Assured operation point
 S_{ar} Assured release point
 according to EN 60947 -5-3

The envelope curves indicate the switch-on and switch-off points of the CSS 180 sensor relative to the target. The maximum offset of the target from sensor axis is approx. 5 mm. Flush-mounting of the sensor or actuator reduces the switching distance. Changes in temperature have only a slight effect on the switching points.



Flush mounting of the sensor CSS 180

The CSS 180 sensor and the CST 180 actuator can be flush-mounted. Flush mounting however reduces the switching distance. The switch point of the sensor is reduced by approx. 1.5 – 2 mm when flush-mounted. The exact reduction depends on the immediate environment and must be determined in situ. When the sensor and actuator protrude 2 mm out of their mountings the switching distance is not reduced.

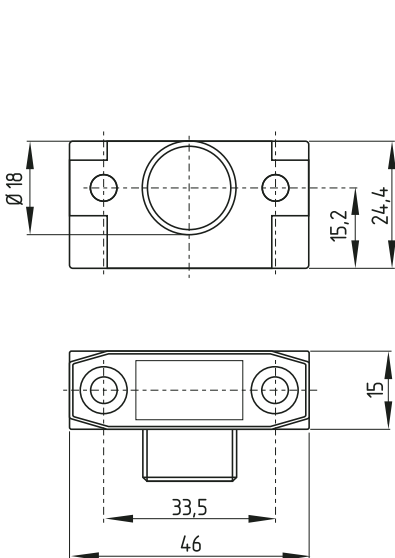

Dimensions of the CST Actuator.

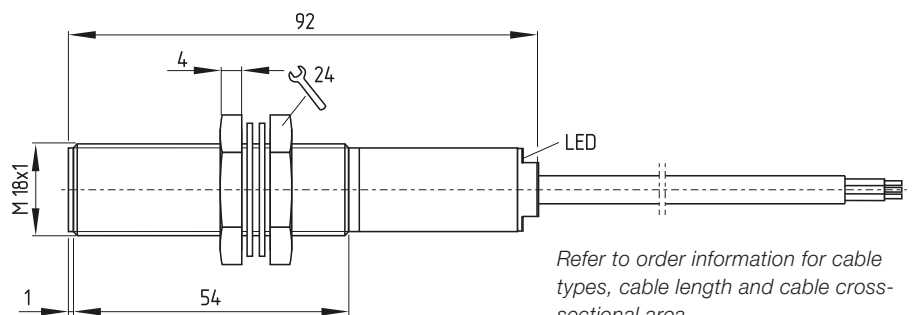

Dimensions of the CSS 180 Safety Sensor.

Refer to order information for cable types, cable length and cable cross-sectional area.

Wiring example

Series connection of CSS-8-180 Safety Sensors in large systems

The sensors have separate input and output cables. The output of one sensor can be directly wired into the input of the next sensor. The sensor chain can be built up over a length of two hundred metres.

Sensors used:

1 Safety Sensor CSS-8-180-2P-E-L:
This sensor has one output cable. It is designed for the beginning of a chain or for use as a single device.

3 Safety Sensors CSS-8-180-2P-Y-L:
These sensors have separate input and output cables. The output of the first sensor is wired into the input of the next sensor and so on. This type of sensor can also be used as the first sensor in a chain, if the supply voltage is bridged to the safety inputs.

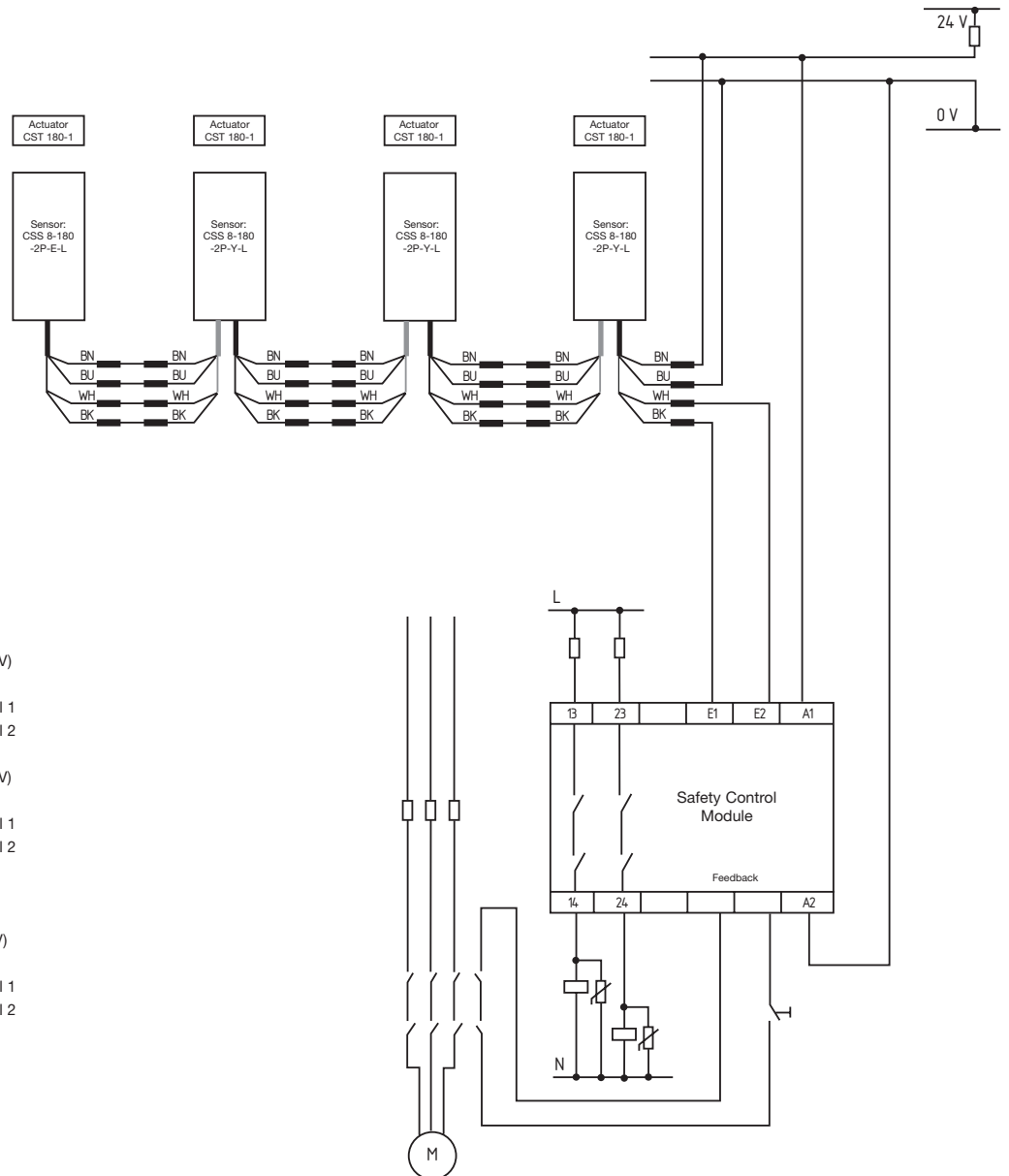

CSS-8-180-2P-Y-L

Input: grey cable
 Operating voltage: (BN) brown P (+24 V)
 (BU) blue 0 V
 Safety input: (WH) white channel 1
 (BK) black channel 2
 output: black cable
 Operating voltage: (BN) brown P (+24 V)
 (BU) blue 0 V
 Safety output: (WH) white channel 1
 (BK) black channel 2

CSS-8-180-2P-E-L

Output: black cable
 Operating voltage: (BN) brown P (+24V)
 (BU) blue 0 V
 Safety output: (WH) white channel 1
 (BK) black channel 2

Wiring example

Series connection of Safety Sensors CSS 180 in small systems with a centralised control cabinet or wiring via junction boxes.

Sensors used:

1 Safety Sensor CSS-8-180-2P+D-E-L:
This sensor has one output cable. It is designed for the beginning of a chain or for use as a single device.

3 Safety Sensors CSS-8-180-2P+D-M-L:
The inputs and outputs of the sensors are brought out in one cable. The sensors are wired together in series in the control cabinet or in junction boxes.

This type of sensor can also be used as the first sensor in a chain, if the supply voltage is bridged to the safety inputs. For very long sensors chains it is recommended to feed the power supply directly to the first sensor in the chain to avoid excessive voltage drop. The safe outputs of the last sensor in the chain are connected to the safety control module.

If junction boxes are used, standard installation cable can be used for the wiring between junctions. When laid together with control cables in a separate cable channel, shielding is not necessary.

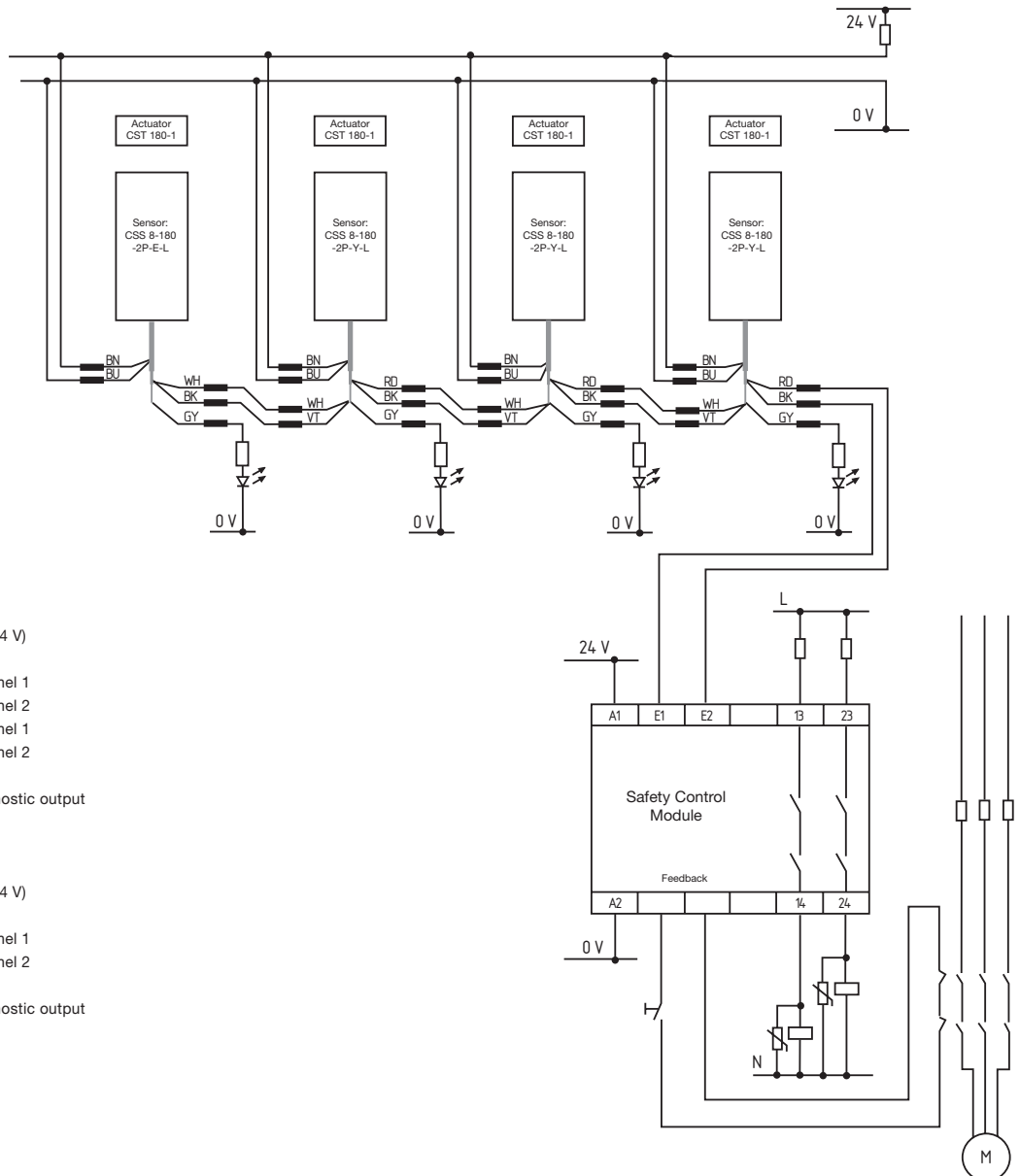

CSS-8-180-2P+D-M-L

Operating voltage: (BN) brown P (+24 V)
(BU) blue 0 V
Safety input: (WH) white channel 1
(VT) violet channel 2
Safety output: (RD) red channel 1
(BK) black channel 2
(GY) grey diagnostic output

CSS-8-180-2P+D-E-L

Operating voltage: (BN) brown P (+24 V)
(BU) blue 0 V
Safety output: (WH) white channel 1
(BK) black channel 2
(GY) grey diagnostic output

Ordering information



Safety Sensor



Actuator

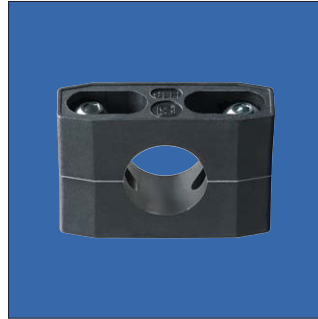

Mounting clamp

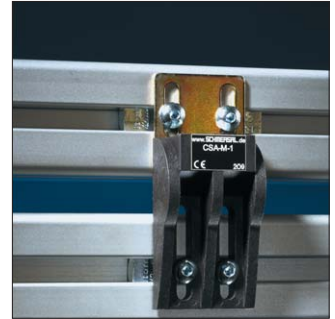

Magnetic latch

Ordering information

Safety Sensors	Cable	Version
CSS- 8- 180- 2P	-E -L 4-wire	End or single device with pre-wired cable
CSS- 8- 180- 2P	-E -LST 4-wire	End or single device, pre-wired cable with connector
CSS- 8- 180- 2P +D	-E -L 5-wire	End or single device with diagnostic output, pre-wired cable
CSS- 8- 180- 2P +D	-E -LST 5-wire	End or single device, diagnostic output, pre-wired cable with connector
CSS- 8- 180- 2P	-Y -L 2 x 4-wire	Series device with double pre-wired cable
CSS- 8- 180- 2P	-Y -LST 2 x 4-wire	Series device with double pre-wired cable with male / female connectors
CSS- 8- 180- 2P +D	-M -L 1 x 7-wire	Multifunction device with diagnostic output, pre-wired cable
CSS- 8- 180- 2P +D	-M -LST 1 x 7-wire	Multifunction device with diagnostic, pre-wired cable with connector

Actuator CST-180- 1

Accessories

CSA- M-1	Magnetic latch
H 18	Mounting clamp

Requirements for the Safety Control Module:

Dual-channel safety inputs, suitable for PNP semiconductor outputs. The internal function tests of the sensor cause the outputs to sporadically switch off for a millisecond. This must be tolerated by the control module. The following safety control modules from the Schmersal programme are suitable for this application: AZR 200 TL, AZR 321 AR, SRB 308 IT, SRB 219 IT

Mounting clamp

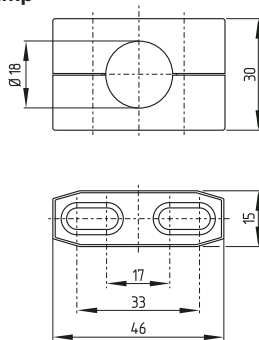

Magnetic latch

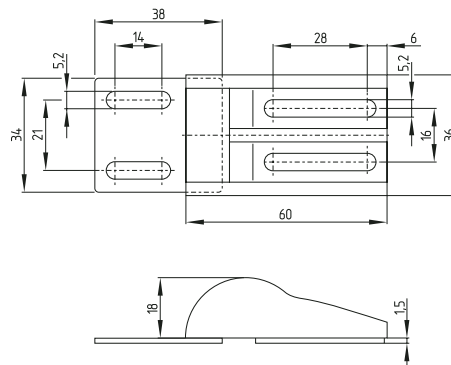

Technical data

Technical data: Safety Sensor CSS 180

Standards	EN 60947-5-3, EN 954-1, IEC 61508
Enclosure	Glass-fibre reinforced thermoplastic
Protection class	IP 65, IP 67
Mode of operation	Inductive
Actuator	CST 180-1
Cable type, depending on version	4 x 0,5 mm ² , 5 x 0,34 mm ² or 7 x 0,25 mm ²
Connecting plug (optional), depending on version	M12, 4-pole, 5-pole or 8-pole
Cable length:	2 m, with 2 connecting cables 2 m + 0,25 m
Switching distances:	
Nominal switching distance S_n	8.0 mm
Indicated limit range S_n	7.0 mm – 8.5 mm
Assured operating distance to EN 60947-5-3	$S_{a0} = 7.0$ mm, $S_{ar} = 9.5$ mm
Hysteresis H	≤ 0.5 mm
Repeatability	≤ 0.2 mm
Ambient conditions:	
Ambient temperature	-25 °C to +55 °C (at +70 °C $I_e = 0.1$ A)
Storage and transport temperature	- 25 °C to +85 °C
Resistance to vibration	10-55 Hz, amplitude 1 mm
Resistance to shock	30 g / 11 ms
Switching frequency f	3 Hz
Response time	≤ 30 ms
Risk time	≤ 30 ms
Electrical characteristics:	
Rated operating voltage U_e	24 VDC -15% / +10%
Rated operating current I_e	1.0 A
No load current I_0	0.05 A
Residual current I_r	≤ 0.5 mA
Protection class	II
Overvoltage category	III
Contamination level	3
Rated impulse withstand voltage U_{imp}	0.8 kV
Rated insulation voltage U_i	32 VAC/VDC
Safety outputs	PNP, short-circuit proof
Output current	Max. 0.5 A per output
Voltage drop on output DU	Max. 0.5 V
Utilisation category	DC12 U_e/I_e 24 VDC / 0.5 A DC13 U_e/I_e 24 VDC / 0.5 A
Signalling output:	PNP, short-circuit proof
Rated operating voltage U_{e2}	Max. 4V below U_e
Rated operating current I_{e2}	Max. 0.05 A
Utilisation category	DC12 U_e/I_e 24 VDC / 0.05 A DC13 U_e/I_e 24 VDC / 0.05 A
Safety standards	
According to EN 954-1	Control Category 4
According to EN 60947-5-3	PDF-M
According to IEC 61508	PFH value < 5,5 x 10 ⁻⁹
	For the calculation of the PFH Value for a machine or system according to IEC 61508, the PFH value for individual sensors must be added together. This is independent of the method of sensor wiring.
BG approval:	In preparation. The certification is based on six sensors in series.

K. A. Schmersal GmbH
Industrielle Sicherheitssysteme
Möddinghofe 30
D-42279 Wuppertal
Tel.: +49-(0)202/64 74-0
Fax: +49-(0)202/64 74-100
Internet: www.schmersal.com
E-Mail: info@schmersal.com