

Solenoid interlock AZM 200
The non-contact interlock.



The non-contact



Solenoid interlocks demand accurate alignment of actuator and device. This requirement is met on new machinery. But during its lifetime, the situation may occur in which the actuator can no longer easily enter the device. As a consequence, both parts become damaged. This in turn leads to machine downtime and repair costs.

Schmersal eliminates this problem with the new, patented AZM 200 solenoid interlock.

Due to newly developed sensor technology from Schmersal, the actuator and interlock can now have an offset of ± 5 mm and the actuator still engages the interlock.

This simplifies the mounting and reduces regular maintenance and adjustment of the safety guard.

As an additional installation feature, the AZM 200 has two slotted mounting holes, enabling a quick and smooth mounting on aluminium profiles or steel frames using just two screws.

The slim, symmetrical design is ideally suited for installation on current aluminium profiles with a minimum width of 40 mm.

With its modern and ergonomic design, the AZM 200 is the right choice of solenoid interlock for all machinery with a high demand on visual appearance.

Three LED's indicate the operating state. Therefore, the operator always knows whether the door is released for unlatching.

This interlock offers enormous advantages particularly for fences around hazardous areas with walk-in access. Due to the one-hand operation of the emergency handle, the hazardous area can be left quickly and safely, even during a power failure – a feature, which is unique on the market.

The AZM 200 increases machine availability through the integrated modern electronics. This is because intelligent diagnosis provides fast trouble-shooting. A fault does not lead to an immediate machine switch-off; the fault is first signalled so that the machine can be progressively shut down in a controlled manner.

The AZM 200 can even be wired in series with other AZM 200 solenoid interlocks and also with the Schmersal safety sensor CSS 180. This feature considerably reduces the wiring costs and simplifies the set-up of safety circuits.

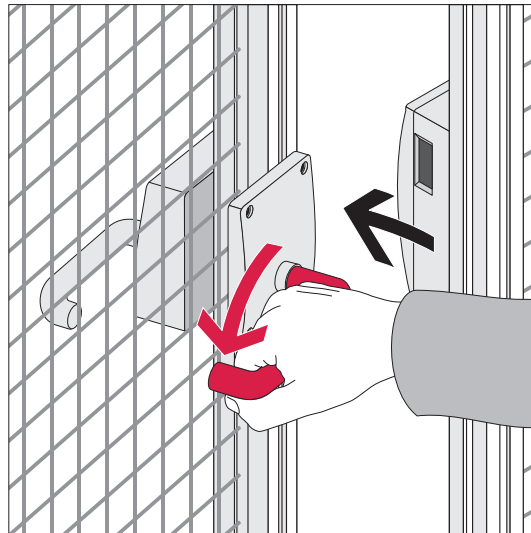

interlock

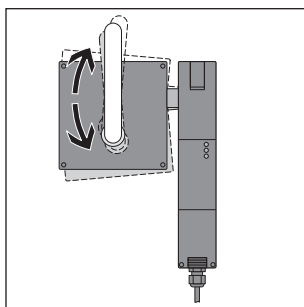
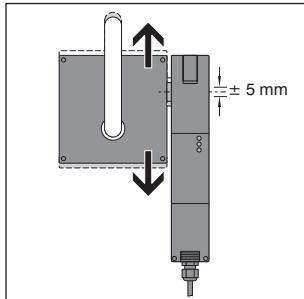
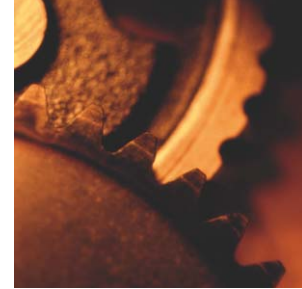

The solenoid interlock enables safeguarding of the guard door up to control category 4 to EN 954-1 using just one interlock, even when multiple interlocks are wired in series. An additional switch on the guard door is no longer necessary. Consequently, along with the reduced wiring costs, the number of control modules needed is also reduced.

The AZM 200 not only complies with the requirements of EN 954-1, it was also developed and certified to IEC 61508, which makes it suitable for applications up to SIL 3.

A SIL 3 certification requires the use of high reliable components inside the device as well as a high resistance to electromagnetic interferences, which is an important quality feature.

The AZM 200 increases machine availability and is an extremely reliable high-efficient device.

Furthermore, the entire system of interlock and actuating unit saves additional door handles and hardware.

The actuator is always inserted into its housing via the ergonomically shaped door handle. This protects the actuator and the operator against damages and injury. This design also impedes tampering with the interlock.

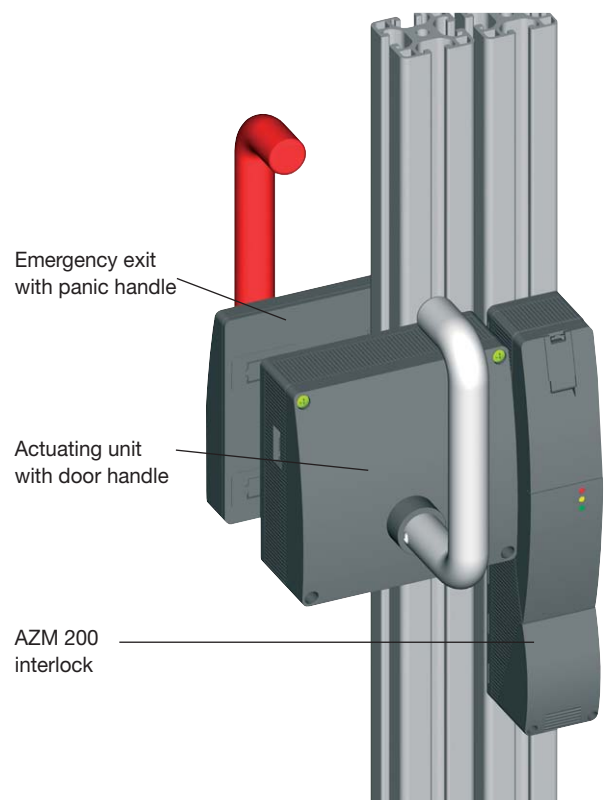

The essential advantages



- Patented system
- Sensor technology permits an offset of ± 5 mm between actuator and interlock
- Control category 4 to EN 954-1 with door detection sensor (without additional second switch)
- Suitable for SIL 3 applications to IEC 61508
- Modern electronics facilitates intelligent diagnosis and increases the availability of machinery, because faults do not lead to the immediate machine switch-off
- Modern and ergonomic design for machinery which places high demands on visual appearance
- Easy mounting with just two screws
- Fine adjustment through mounting slots in the device and the actuator
- Slim, symmetrical device, perfectly suited for aluminium profiles with a minimum width of 40 mm
- LED indication of the operational state simplifies operation
- Emergency release with one hand possible, even in de-energised condition
- Smooth and intuitive operation
- No risk of injury from protruding actuator
- Saves additional door handles
- Does not protrude into the door opening
- Manual release from both sides

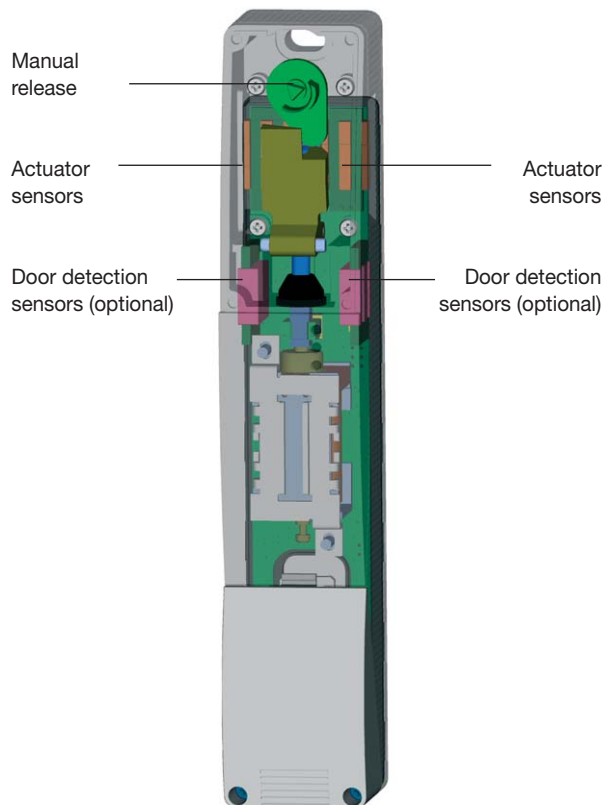



Mounting and application

The AZM 200 was especially developed for applications at hinged guards and fences. The two slotted holes enable a fast and smooth installation on aluminium profiles or steel frames. In this way, the interlock can be perfectly adjusted and aligned with the doorpost, even afterwards, and does not protrude into the door opening.

The actuator unit is also fixed with two screws. The link blocks allow for an accurate horizontal and vertical adjustment, both of the actuator unit and the optional emergency exit.

This installation method does not require any additional mounting plates for the interlock and the actuating unit.

Only the supplied square bar must be cut to the right length.

Once the individual components (interlock, actuator unit and optionally the emergency exit) are fitted, the mounting screws are invisible, thus offering a high protection against tampering.

The system is fit for any fence with a door gap restricted to $6,5 \pm 1,5$ mm and a door opening of at least 400 mm.

Door hinge on left-hand side

Door hinge on right-hand side

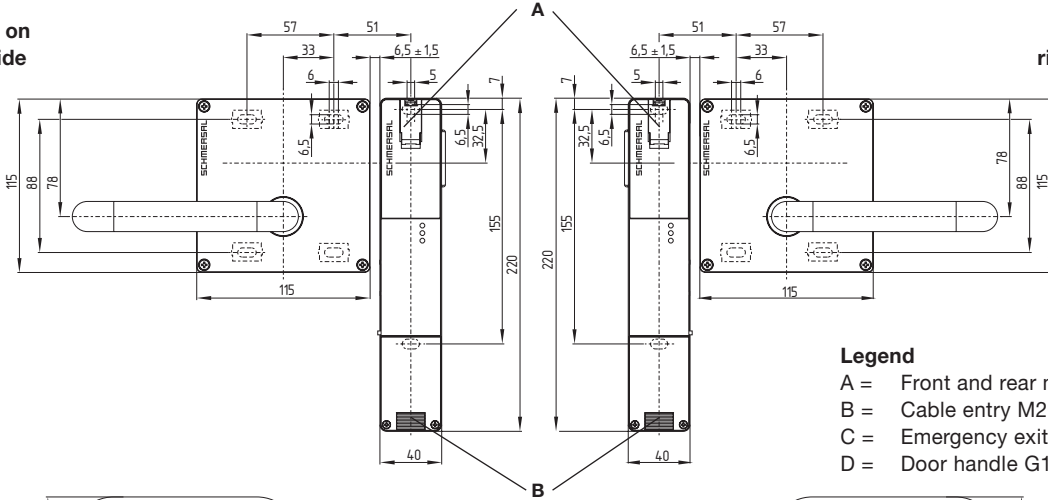

- Legend**
 A = Front and rear manual release
 B = Cable entry M20 x 1,5
 C = Emergency exit P1
 D = Door handle G1

Diagnosis



The integrated electronics of the AZM 200 allow for an extensive diagnosis of the different operational states of the device, thus facilitating the integration in the machine control as well as fast fault detection and trouble-shooting. This feature increases the runtime of the machinery.

The AZM 200 has three LED's indicating its current state. Furthermore, the combination of the safety outputs and the diagnostic output informs the machine control about the operational state of the AZM 200.

Meaning of the three LED's:

- Green = Supply voltage 24 VDC available
- Yellow = blinking: door closed, unlocked
 - = continuous: door locked
- Red = blinking: error code (see below)
 - = continuous: internal error

The diagnostic output "OUT" has two states: 0 V, when the actuator is not inserted in the interlock and 24 VDC, when the actuator has been detected (i.e. engaged).

When the interlock has locked the door, both the safety outputs Y1 and Y2 and the diagnostic output OUT supply 24 VDC.

In case of a system error, which does not completely deactivate the safety function of the device (e.g. cross-wire) and therefore may only be tolerated for a certain time according to IEC 61508, the safety outputs are not immediately switched off. They keep supplying 24 VDC; the diagnostic output however immediately drops to 0 V.

From this combination of safety outputs and diagnostic output, the machine control can immediately detect the error and progressively shut down the machine in a controlled manner, before the outputs of the AZM 200 drop to 0 V, thus triggering an immediately standstill of the machine.

In case of such an error, the safety outputs are switched off after 30 minutes.



Diagnosis



The blinking sequence of the red LED of the AZM 200 identifies the active error. The following errors are indicated:

Indication (red)		Meaning
1 blinking impulse		Error output Y1
2 blinking impulses		Error output Y2
3 blinking impulses		Cross-wire
4 blinking impulses		Temperature too high
5 blinking impulses		Target error
6 blinking impulses		Error target combination
7 blinking impulses		Error AD values
8 blinking impulses		Error transmission voltage
9 blinking impulses		Channel error
Continuous red		Error

The diagnostics function of the AZM 200 solenoid interlock

The solenoid interlock signals the operational state and possible errors through the coloured LED's, which are installed to the front of the device.

The diagnostic output "OUT" is signalling errors before the safety outputs are switched off, thus enabling a controlled shut-down of the machine.

LED	State AZM 200	Diagnostic output	Safety outputs
green	Supply voltage	0 V or 24 V	0 V or 24 V
yellow	Actuator inserted and locked	24 V	24 V (if X1=X2 = 24 V)
blinking yellow	Actuator inserted and not locked	24 V	0 V
blinking red (1-9 impulses)	Error: see blinking codes	10 s delayed: 0 V	see table below
continuous red	internal error	0 V	0 V

Blinking codes (red)	Meaning	Autonomous switch-off after	Cause
1 blinking impulse	Error output Y1	30 min	Error in output test or voltage at output "Y1", although the output is switched off
2 blinking impulses	Error output Y2	30 min	Error in output test or voltage at output "Y2", although the output is switched off
3 blinking impulses	Cross-wire	30 min	Cross-wire between the output cables or error at both outputs
4 blinking impulses	Temperature too high	30 min	Temperature measurement indicates too high an inner temperature
5 blinking impulses	Target error	0 min	The difference between the code (frequency) of the detected target and the set value is too large, false target
6 blinking impulses	Error target combination	0 min	An invalid combination of targets was detected at the 4 coils of the AZM. (Current setting: latching bolt detected & door target not detected => latch breakage or tampering attempt)
7 blinking impulses	Error AD values	30 min	Internal hardware error
8 blinking impulses	Error transmission voltage	0 min	Supply voltage too low or defective internal voltage control
9 blinking impulses	Channel error	30 min	Data comparison between the channels leads to differences in the signal evaluation because of an internal hardware error

Electrical wiring



The AZM 200 is simply integrated in the safety circuit using the terminal block in the wiring compartment.

The safety outputs Y1 and Y2 consists of p-type short-circuit proof transistors. Both outputs must be connected to the inputs of the safety control module used.

In case of series wiring of multiple AZM 200's, the outputs are connected to the safety inputs X1 and X2 of the next device.

The magnet is energised through the "IN" terminal, i.e. when the terminal is connected to 24 VDC, the interlock is either locked (Power-To-Lock) or unlocked (Spring-To-Lock).

The diagnostic output "OUT" signals the presence of the correct actuator in the interlock. If 24 VDC is supplied, the door is closed, but not necessarily locked. When no voltage is supplied, the actuator is not engaged in the interlock.

In case of single device wiring, the bridge between the "24 V" terminal and the "X1" and "X2" terminals must be established; for series wiring, this bridge must only be established in the first device of the series.

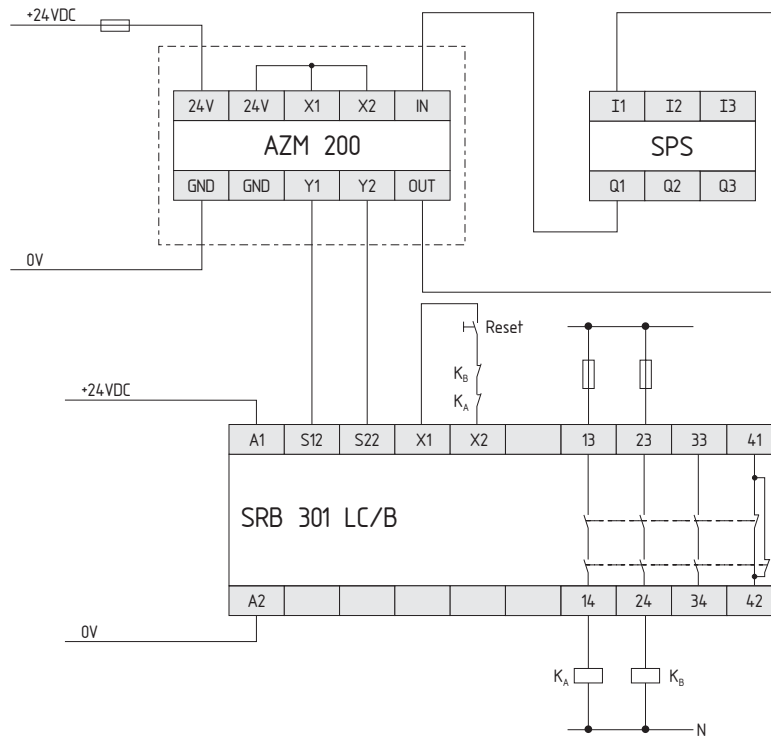

Wiring example: Single device wiring



Wiring compartment AZM 200

24V	24V	X1	X2	IN
AZM 200				
GND	GND	Y1	Y2	OUT

Meaning	Terminal
Supply Voltage	24 V
Supply Voltage	24 V
Safety Input 1	X1
Safety Input 2	X2
Magnet Actuation	IN
Ground	GND
Ground	GND
Safety Output 1	Y1
Safety Output 2	Y2
Diagnostic Output	OUT

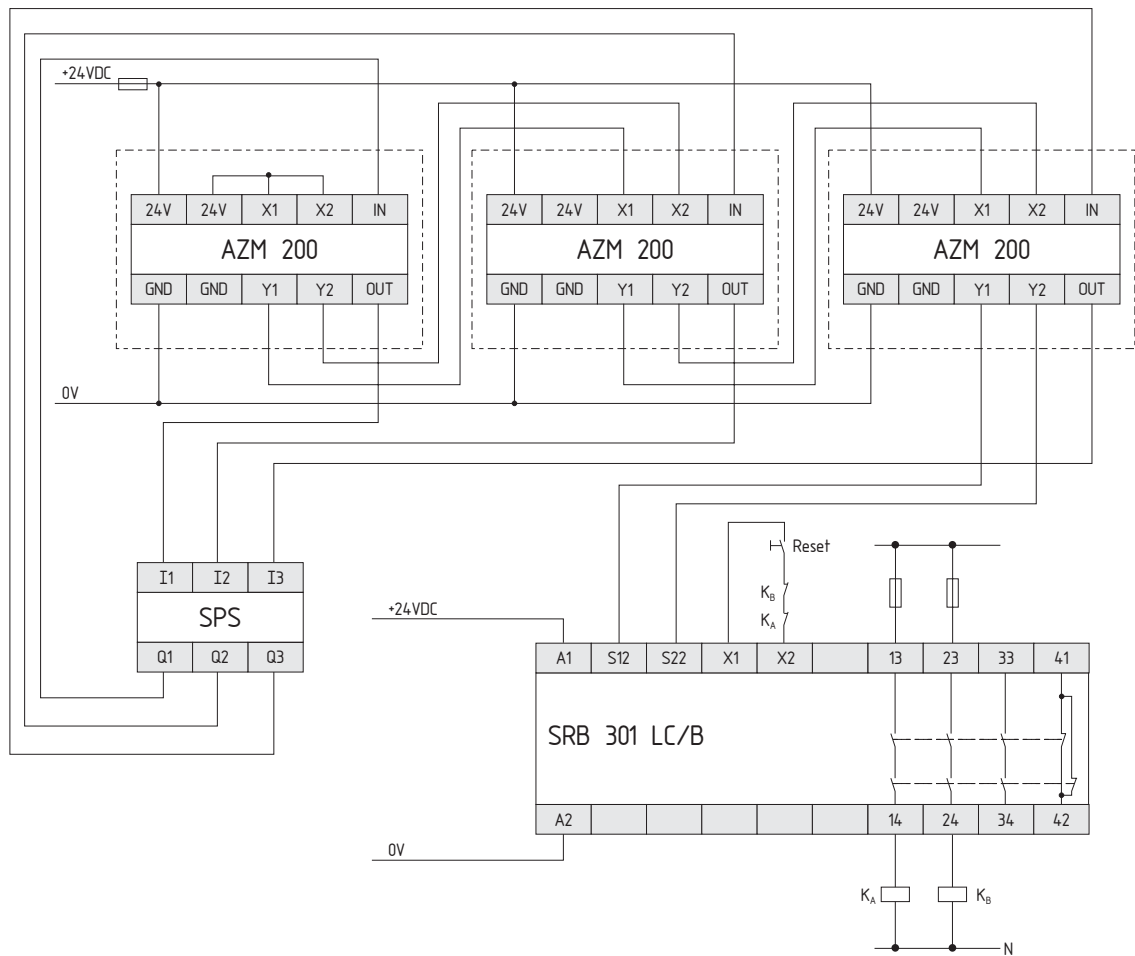

Wiring example: Series wiring of 3 AZM 200

Solenoid interlock AZM 200 – The non-contact interlock

Interlock

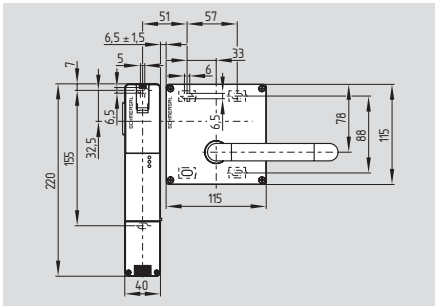

- Sensor technology permits an offset of ± 5 mm between actuator and interlock
- Control category 4 to EN 954-1 with door detection sensor (without additional second switch)
- Suitable for SIL 3 applications to IEC 61508
- Intelligent diagnosis
- Modern and ergonomic design
- Easy fitting
- Accurate adjustment through slotted holes
- LED indication of operating states (3 LED's)
- One-hand emergency release, even in de-energised condition
- Easy and intuitive operation
- No risk of injury from a protruding actuator
- Saves additional door handles
- Does not protrude into the door opening
- Emergency exit from both sides

Actuator unit

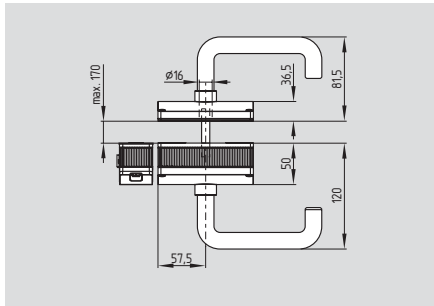

The interlock and the actuator unit must be ordered separately. Below, the ordering codes for both units are indicated.

Technical data

Standards: IEC/EN 60947-5-1, EN 954-1, IEC/EN 61508, IEC 61508
 Enclosure: glass-fibre reinforced thermoplastic, auto-extinguishing
 Mechanical life: > 1 million operations
 F_{max} : 2300 N
 Latching force: 30 N
 Protection class: IP 67
 Insulation protection class: II, III
 Over-voltage category: III
 Degree of pollution: 3
 Termination: screw terminals or cage clamps
 Cable section: min. 0,25 mm², max. 1,5 mm² (incl. conductor ferrules)
 Cable entry: M 20 x 1.5
Series wiring: max. 16 devices
 Cable length: max. 200m
 (Cable length and cable section alter the voltage drop depending on the output current)

Ambient conditions:
 Ambient temperature: -25 °C ... +60 °C
 Storage and transport temperature: -25 °C ... +85 °C
 Resistance to vibration: 10...55 Hz, amplitude 1mm
 Resistance to shock: 30 g / 11 ms
 Switching frequency: 1 Hz
 Response time: < 30 ms
 Duration of risk: < 30 ms
 Time to readiness: < 2 s

Electrical data:
 Rated operating voltage U_g : 24 VDC -15% / +10%
 Rated operating current I_g : 1 A
 No-load current I_0 : max. 0,5 A
 Rated impulse withstand voltage U_{imp} : 800 V
 Rated insulation voltage U_i : 32 VDC
 Fuse rating: internally short-circuit proof
 Device insulation: to UL 508 ≤ 4 A; depending on the number of devices and loads (Y1, Y2 and OUT)
 Leakage current I_r : ≤ 0.5 mA

Safety inputs "X1" and "X2":
 Voltage range -3V ... 5V: low
 Voltage range 15V ... 30V: high > 2 mA at 24 V

Safety outputs "Y1" and "Y2": p-type, short-circuit proof
 Rated operating voltage U_{e1} : max. 4 V under U_g

Rated operating current I_{e1} : max. 0.25 A
 Utilisation category: DC-13

Diagnostic output "OUT": p-type, short-circuit proof
 Rated operating voltage U_{e2} : max. 4 V under U_g

Rated operating current I_{e2} : max. 0.05A
 Utilisation category: DC-13

Magnet actuation "IN":
 Voltage range -3V ... 5V: low
 Voltage range 15V ... 30V: high >5 mA at 24 V
 Magnet: 100% ED

Classification:
 to EN 954-1: up to control category 4 (with appropriate circuit)
 to IEC 61508: PFH value = under preparation, suitable for SIL 3

Approvals

under preparation

Approvals

under preparation

Ordering data

AZM 200①-②-1P2P③

Nr.	Insert	Description
①	SK	Screw terminals
	CC	Cage clamps
	ST	Connector (M23)
②		Without door detection sensors
	T	With door detection sensors
③		Power to unlock
	a	Power to lock

Ordering data

AZ/AZM 200-B30-① ② ③ ④ ⑤

Nr.	Insert	Description
①	L	Door hinge on left-hand side
	R	Door hinge on right-hand side (view point towards the hazardous area)
②		without
	T	with door detection sensor
③		Mounting inside
	A	Mounting outside the hazardous area
④	G1	Door handle
	G2	Rotary button
⑤		without emergency exit
	P1	with emergency exit

Solenoid interlock AZM 200 – The non-contact interlock

System components



System components

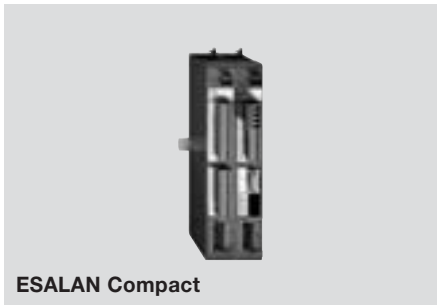
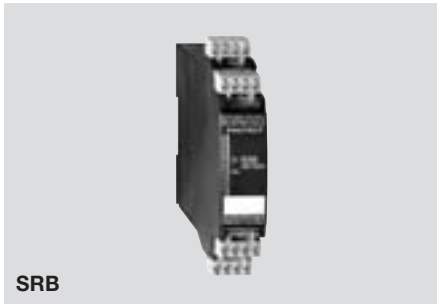

Note

Possible safety control modules

The safety outputs of the AZM 200 are p-type transistor outputs. Taking the self-test feature of these outputs into account, the safety control modules must tolerate a brief switching-off of the outputs. The cross-wire detection must be deactivated.

The following modules allow for a trouble-free functioning in combination with the AZM 200:

- AES 1135
- AES 1235
- AZR 200 TL
- AZR 200 AL
- AZR 301 AL
- AZR 311 TL
- AZR 321 AR
- SRB 308 IT
- SRB 219 IT
- SRB 324 ST
- SRB 301 LC/B
- SRB-C.46
- SRB-C.47
- SRB-NA-R-C.18
- SRB-NA-R-C.21
- SRB-NA-R-C.22
- SRB-NA-R-C.27
- SRB-NA-R-C.33-24V
- SRB-NA-R-C.34
- SRB-NA-R-C.35
- SRB-NA-R-C.36
- SRB-NA-R-C.38
- SCR 1R
- SCR 402R-301
- ESALAN Compact

Further information about these devices can be found in our main catalogue "Safety Technology".

The modules and the structure of the entire safety circuit are determining the obtainable control categories.

Ordering data

Door handle for actuator	G1
Rotary button for actuator	G2

K.A. Schmersal GmbH
Industrielle Sicherheitssysteme

Möddinghofe 30
D-42279 Wuppertal
Postfach 24 02 63
D-42232 Wuppertal

Telefon +49 - (0)2 02 - 64 74 - 0
Telefax +49 - (0)2 02 - 64 74 - 1 00

E-Mail info@schmersal.de
Internet <http://www.schmersal.com>